

Multiaxis Three Dimensional (3D) Woven Fabric

Kadir Bilisik

*Erciyes University Department of Textile Engineering
Turkey*

1. Introduction

Textile structural composites are widely used in various industrial sections, such as civil and defense (Dow and Dexter, 1997; Kamiya et al., 2000) as they have some better specific properties compared to the basic materials such as metal and ceramics (Ko & Chou 1989; Chou, 1992). Research conducted on textile structural composites indicated that they can be considered as alternative materials since they are delamination-free and damage tolerant (Cox et al, 1993; Ko & Chou 1989). From a textile processing viewpoint they are readily available, cheap, and not labour intensive (Dow and Dexter, 1997). The textile preform fabrication is done by weaving, braiding, knitting, stitching, and by using nonwoven techniques, and they can be chosen generally based on the end-use requirements. Originally three dimensional (3D) preforms can be classified according to fiber interlacement types. Simple 3D preform consists of two dimensional (2D) fabrics and is stitched depending on stack sequence. More sophisticated 3D preforms are fabricated by specially designed automated loom and manufactured to near-net shape to reduce scrap (Brandt et. al., 2001; Mohamed, 1990). However, it is mentioned that their low in-plane properties are partly due to through-the-thickness fiber reinforcement (Bilisik and Mohamed, 1994; Dow and Dexter, 1997; Kamiya et al., 2000). Multiaxis knitted preform, which has four fiber sets as \pm bias, warp(0°) and weft(90°) and stitching fibers enhances in-plane properties (Dexter and Hasko, 1996). It was explained that multiaxis knitted preform suffers from limitation in fiber architecture, through-thickness reinforcement due to the thermoplastic stitching thread and three dimensional shaping during molding (Ko & Chou 1989).

Multiaxis 3D woven preform is developed in the specially developed multiaxis 3D weaving and it's in-plane properties are improved by orienting the fiber in the preform (Mohamed and Bilisik, 1995; Uchida et al, 2000). The aim of this chapter is to review the 3D fabrics, production methods and techniques. Properties of 3D woven composites are also provided with possible specific end-uses.

2. Classifications of 3D fabrics

3D preforms were classified based on various parameters. These parameters depend on the fiber type and formation, fiber orientation and interlacements and micro and macro unit cells structures. One of the general classification schemes has been proposed by Ko and Chou (1989). Another classification scheme has been proposed depending upon yarn

Direction	Three dimensional weaving			
	Woven		Orthogonal nonwoven	
	Cartesian	Polar	Cartesian	Polar
2 or 3	Angle interlock <ul style="list-style-type: none"> • Layer-to-layer • Through-the-thickness 	Tubular	Weft- insertion	Weft-winding and sewing
	Core structure <ul style="list-style-type: none"> • Rectangular • Triangular • Double layer • Angularly oriented • Diamond 			
3	Plain <ul style="list-style-type: none"> • Plain weft laid-in • Plain binder laid-in 	Plain <ul style="list-style-type: none"> • Plain radial laid-in • Plain circumferential laid-in 	Open- lattice Solid	Tubular
	Twill <ul style="list-style-type: none"> • Twill weft laid-in • Twill binder laid-in 	Twill <ul style="list-style-type: none"> • Twill radial laid-in • Twill circumferential laid-in 		
	Satin <ul style="list-style-type: none"> • Satin weft laid-in • Satin binder laid-in 	Satin <ul style="list-style-type: none"> • Satin radial laid-in • Satin circumferential laid-in 		
4	Plain <ul style="list-style-type: none"> • Plain laid-in 	Plain <ul style="list-style-type: none"> • Plain radial laid-in • Plain circumferential laid-in 	Corner across Face across Derivative structures <ul style="list-style-type: none"> • Corner- Face-Orthogonal • Corner- Face-Orthogonal • Corner-Orthogonal 	Tubular
	Twill <ul style="list-style-type: none"> • Twill laid-in 	Twill <ul style="list-style-type: none"> • Twill radial laid-in • Twill circumferential laid-in 		
	Satin <ul style="list-style-type: none"> • Satin laid-in 	Satin <ul style="list-style-type: none"> • Satin radial laid-in • Satin circumferential laid-in 		

5	Plain • Plain laid-in	Plain • Plain radial laid-in • Plain circumferential laid-in	Solid	Tubular
	Twill • Twill laid-in	Twill • Twill radial laid-in • Twill circumferential laid-in		
	Satin • Satin laid-in	Satin • Satin radial laid-in • Satin circumferential laid-in		
6 to 15	Rectangular array	Rectangular array	Rectangular array	Rectangular array
	Hexagonal array	Hexagonal array	Hexagonal array	Hexagonal array

Table 1. The classification of three dimensional weaving based on interlacement and fiber axis (Bilisik, 1991).

interlacement and type of processing (Khokar, 2002a). In this scheme, 3D woven preform is divided into orthogonal and multiaxis fabrics and their process have been categorized as traditional or new weaving, and specially designed looms. Chen (2007) categorized 3D woven preform based on macro geometry where 3D woven fabrics are considered solid, hollow, shell and nodal forms. Bilisik (1991) proposes more specific classification scheme of 3D woven preform based on type of interlacements, yarn orientation and number of yarn sets as shown in Table 1. In this scheme, 3D woven fabrics are divided in two parts as fully interlaced 3D woven and non-interlaced orthogonal woven. They are further sub divided based on reinforcement directions which are from 2 to 15 at rectangular or hexagonal arrays and macro geometry as cartesian and polar forms. These classification schemes can be useful for development of fabric and weaving process for further researches.

3. 3D Fabric structure and method to weave

3.1 2D fabric

2D woven fabric is the most widely used material in the composite industry at about 70%. 2D woven fabric has two yarn sets as warp(0°) and filling(90°) and interlaced to each other to form the surface. It has basically plain, twill and satin weaves which are produced by traditional weaving as shown in Figure 1. But, 2D woven fabric in rigid form suffers from its poor impact resistance because of crimp, low delamination strength because of the lack of binder fibers (Z-fibers) to the thickness direction and low in-plane shear properties because no off-axis fiber orientation other than material principal direction (Chou, 1992). Although through-the-thickness reinforcement eliminates the delamination weakness, this reduces the in-plane properties (Dow and Dexter, 1997, Kamiya et al., 2000). On the other hand, uni-weave structure was developed. The structure has one yarn set as warp (0°) and multiple warp yarns were locked by the stitching yarns (Cox and Flanagan, 1997).

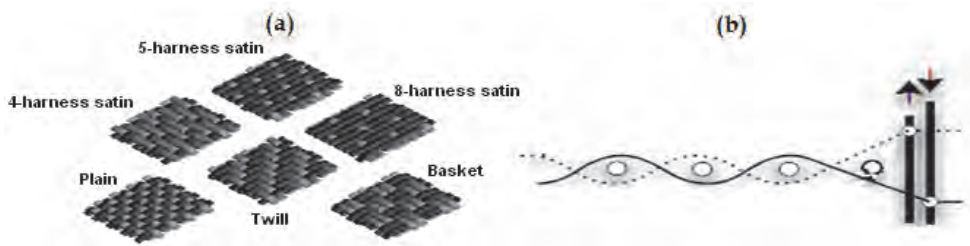

Fig. 1. 2D various woven fabrics (a) and schematic view of processing (b) (Chou, 1992).

Bi-axial non-crimped fabric was developed to replace the unidirectional cross-ply lamina structure (Bhatnagar and Parrish, 2006). Fabric has basically two sets of fibers as filling and warp and locking fibers. Warp positioned to 0° direction and filling by down on the warp layer to the cross-direction (90°) and two sets of fibers are locked by two sets of stitching yarns' one is directed to 0° and the other is directed to 90° . Traditional weaving loom was modified to produce such fabrics. Additional warp beam and filling insertions are mounted on the loom. Also, it is demonstrated that 3D shell shapes with high modulus fibers can be knitted by weft knitting machine with a fabric control sinker device as shown in Figure 2.

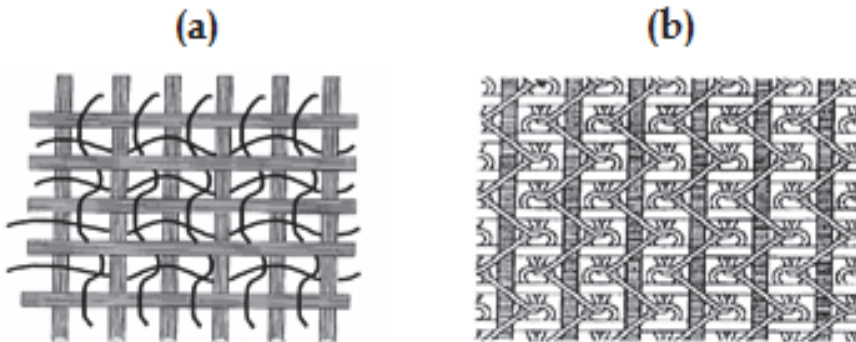

Fig. 2. Non-interlace woven fabric (a) and warp inserted knitted fabric (b) (Bhatnagar & Parrish, 2006).

3.2 Triaxial fabrics

Triaxial weave has basically three sets of yarns as \pm bias (\pm warp) and filling (Dow, 1969). They interlaced to each other at about 60° angle to form fabric as shown in Figure 3. The interlacement is the similar with the traditional fabric which means one set of yarns is above and below to another and repeats through the fabric width and length. Generally, the fabric has large open areas between the interlacements. Dense fabrics can also be produced. However, it may not be woven in a very dense structure compared to the traditional fabrics. This process has mainly open reed. Triaxial fabrics have been developed basically in two variants. One is loose-weave and the other is tight weave. The structure was evaluated and concluded that the open-weave triaxial fabric has certain stability and shear stiffness to $\pm 45^\circ$ direction compared to the biaxial fabrics and has more isotropy (Dow and Tranfield, 1970).

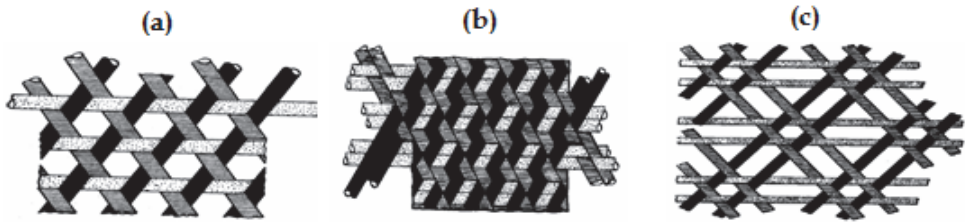

Fig. 3. Triaxial woven fabrics; loose fabric (a), tight fabric (b) and one variant of triaxial woven fabric (c) (Dow, 1969).

The machine consists of multiple \pm warp beams, filling insertion, open beat-up, rotating heddle and take up. The \pm warp yarn systems are taken from rotating warp beams located above the weaving machine. After leaving the warp beams, the warp ends are separated into two layers and brought vertically into the interlacing zone. The two yarn layers move in opposite directions i.e., the front layer to the right and the rear layer to the left. When the outmost warp end has reached the edge of the fabric, the motion of the warp layers is reversed so that the front layer moves to the left and the rear layer to the right as shown in Figure 4. As a result, the warp makes the bias intersecting in the fabric. Shedding is controlled by special hook heddles which are shifted after each pick so that in principle they are describing a circular motion. The pick is beaten up by two comb-like reeds which are arranged in opposite each other in front of and behind the warp layers, penetrate into the yarn layer after each weft insertion and thus beat the pick against the fell of the cloth.

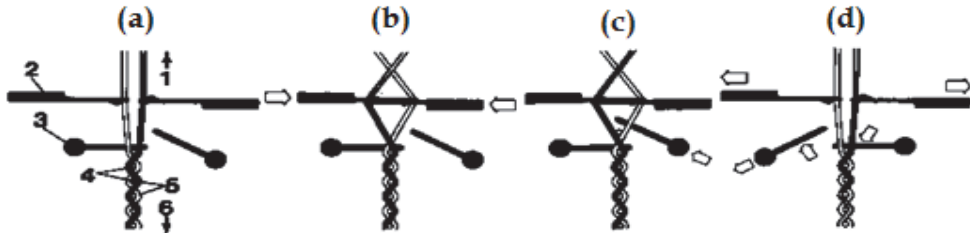

Fig. 4. The schematic views of weaving method of triaxial woven fabrics; bias orientation (a), shedding (b), beat-up (c) and take-up (d) (Dow, 1969).

A century ago, the multiaxis fabric, which has \pm bias, warp(axial) and filling, was developed for garment and upholstery applications (Goldstein, 1939). The yarn used in weaving is slit cane. The machine principal operation is the same with triaxial weaving loom. A loom consists of bias creel which is rotated; \pm bias indexing and rotating unit; axial warp feeding; rigid rapier type filling insertion and take up units.

Tetra-axial woven fabric was introduced for structural tension member applications. Fabric has four yarn sets as \pm bias, filling and warp (Kazumara, 1988). They are interlaced all together similar with the traditional woven fabric. So, the fabric properties enhance the longitudinal direction. The process has rotatable bias bobbins unit, a pair of pitched bias cylinders, bias shift mechanism, shedding unit, filling insertion and warp (0°) insertion units. After the bias bobbins rotate to incline the yarns, helical slotted bias cylinders rotate to shift the bias one step as similar with the indexing mechanism. Then, bias transfer

mechanism changes the position of the end of bias yarns. Shedding bars push the bias yarns to make opening for the filling insertion. Filling is inserted by rapier and take-up advances the fabric to continue the next weaving cycle.

Another tetra-axial fabric has four fiber sets as \pm bias, warp and filling. In fabric, warp and filling have no interlacement points with each other. Filling lays down under the warp and \pm bias yarns and locks all yarns together to provide fabric integrity (Mamiliano, 1994). In this way, fabric has isotropic properties to principal and bias directions. The process has rotatable bias feeding system, \pm bias orientation unit, shedding bars unit, warp feeding, filling insertion and take-up. After bias feeding unit rotates one bobbin distance, \pm bias system rotates just one yarn distance. Shedding bars push the \pm bias fiber sets to each other to make open space for filling insertion. Filling is inserted by rapier and take-up delivers the fabric. The fabric called quart-axial has four sets of fibers as \pm bias, warp and filling yarns as shown in Figure 5. All fiber sets are interlaced to each other to form the fabric structure (Lida et al, 1995). However, warp yarns are introduced to the fabric at selected places depending upon the end-use.

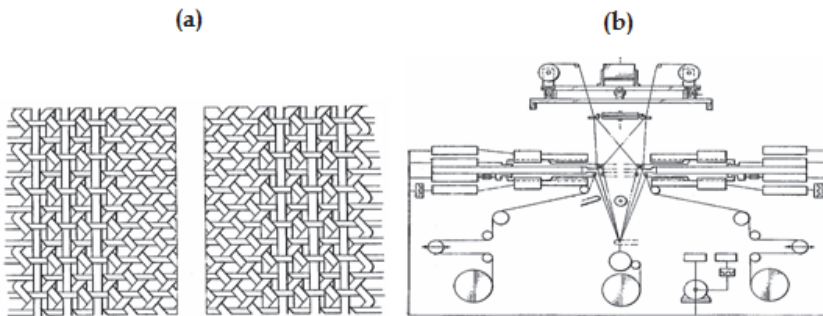

Fig. 5. Quart-axial woven fabric (a) and weaving loom (b) (Lida et al., 1995).

The process includes rotatable \pm bias yarn beams or bobbins, close eye hook needle assembly, warp yarn feeding unit, filling insertion unit, open reed for beat-up and take-up. After the \pm bias yarns rotation just one bobbin distance, heddles are shifted to one heddle distance. Then warp is fed to the weaving zone and heddles move to each other selectively to form the shed. Filling insertion takes place and open reed beats the filling to the fabric formation line. Take-up removes the fabric from the weaving zone.

3.3 3D orthogonal fabric

3D orthogonal woven preforms have three yarn sets: warp, filling, and z-yarns (Bilisik, 2009a). These sets of yarns are all interlaced to form the structure wherein warp yarns were longitudinal and the others were orthogonal. Filling yarns are inserted between the warp layers and double picks were formed. The z-yarns are used for binding the other yarn sets to provide the structural integrity. The unit cell of the structure is given in Figure 6.

A state-of-the-art weaving loom was modified to produce 3D orthogonal woven fabric (Deemey, 2002). For instance, one of the looms which has three rigid rapier insertions with dobby type shed control systems was converted to produce 3D woven preform as seen in Figure 7. The new weaving loom was also designed to produce various sectional 3D woven preform fabrics (Mohamed and Zhang, 1992).

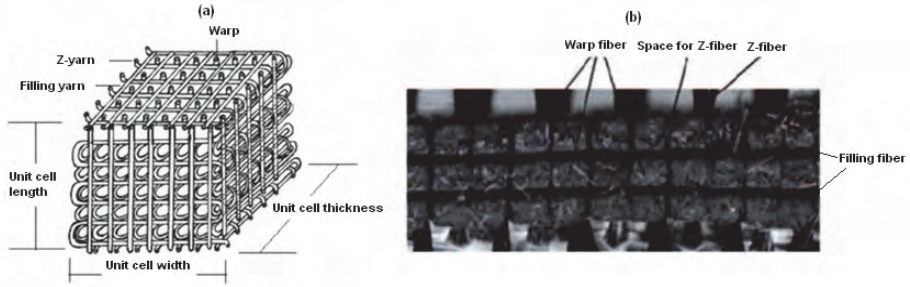

Fig. 6. 3D orthogonal woven unit cell; schematic (a) and 3D woven carbon fabric perform (b) (Bilisik, 2009a).

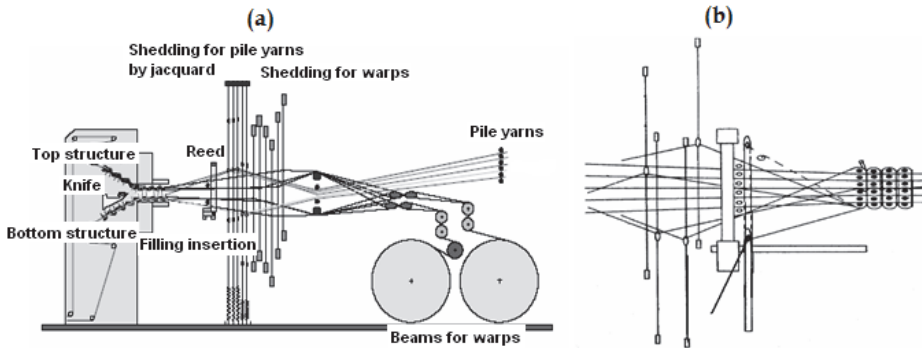

Fig. 7. Traditional weaving loom (a) and new weaving loom (b) producing 3D orthogonal woven fabrics (Deemey, 2002; Mohamed and Zhang, 1992).

On the other hand, specially designed weaving looms for 3D woven orthogonal woven preform were developed to make part manufacturing for structural applications as billet and conical frustum. They are shown in Figure 8. First loom was developed based on needle insertion principle (King, 1977), whereas second loom was developed on the rapier-tube insertion principle (Fukuta et al, 1974).

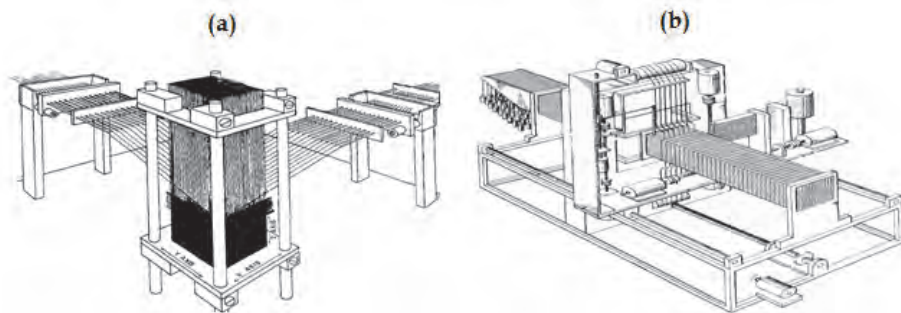

Fig. 8. 3D weaving looms for thick part manufacturing based on needle (a) and rapier (b) principles (King, 1977; Fukuta et al, 1974).

3D angle interlock fabrics were fabricated by 3D weaving loom (Crawford, 1985). They are considered as layer-to-layer and through-the-thickness fabrics as shown in Figure 9. Layer-to-layer fabric has four sets of yarns as filling, \pm bias and stuffer yarns (warp). \pm Bias yarns oriented at thickness direction and interlaced with several filling yarns. Bias yarns made zig-zag movement at the thickness direction of the structure and changed course in the structure to the machine direction. Through-the-thickness fabric has again four sets of fibers as \pm bias, stuffer yarn (warp) and fillings. \pm Bias yarns are oriented at the thickness direction of the structure. Each bias is oriented until coming to the top or bottom face of the structure. Then, the bias yarn is moved towards top or bottom faces until it comes to the edge. Bias yarns are locked by several filling yarns according to the number of layers.



Fig. 9. 3D angle interlock fabrics (a) and schematic view of 3D weaving loom (b) (Khokar, 2001).

Another type of 3D orthogonal woven fabric, which pultruded rod is layered, was introduced. \pm Bias yarns were inserted between the diagonal rows and columns for opening warp layers at a cross-section of the woven preform structure (Evans, 1999).

The process includes \pm bias insertion needle assembly, warp layer assembly and hook holder assembly as shown in Figure 10. Warp yarns are arranged in matrix array according to preform cross-section. A pair of multiple latch needle insertion systems inserts \pm bias yarns at cross-section of the structure at an angle about 60° . Loop holder fingers secure the bias loop for the next bias insertion and passes to the previous loop.

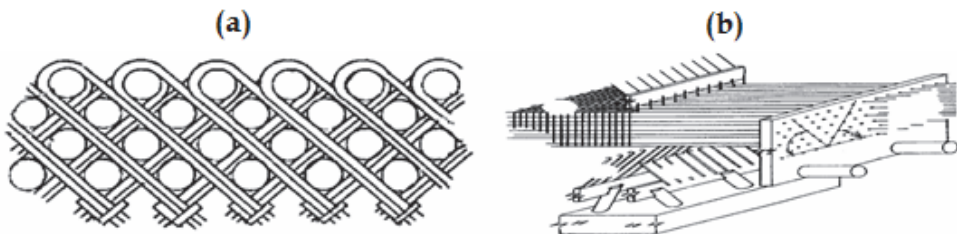

Fig. 10. 3D orthogonal fabric at an angle in cross-section (a) and production loom (b) (Evans, 1999).

3D circular weaving (or 3D polar weaving) was also developed (Yasui et al., 1992). A preform has mainly three sets of yarn: axial, radial and circumferential for cylindrical shapes and additional of the central yarns for rod formation as shown in Figure 11. The device has a rotating table for holding the axial yarns, a pair of carriers which extend vertically up and

down to insert the radial yarn and each carrier includes several radial yarn bobbins and finally a guide frame for regulating the weaving position. A circumferential yarn bobbin is placed on the radial position of the axial yarns. After the circumferential yarn will be wound over the radial yarn which is vertically positioned, the radial yarn is placed radially to the outer ring of the preform. The exchanging of the bobbins results in a large shedding motion which may cause fiber damage.

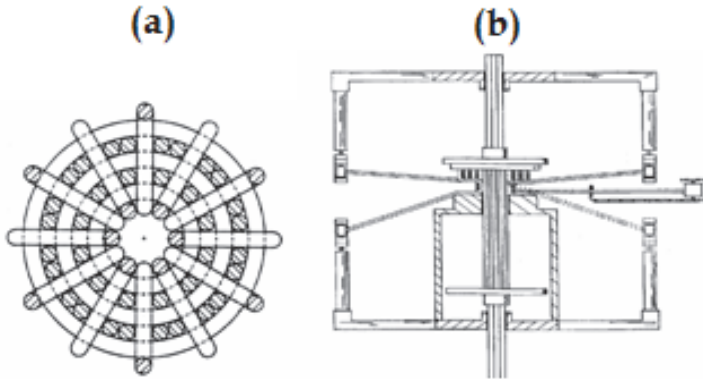

Fig. 11. 3D circular woven perform (a) and weaving loom schematic (b) (Yasui et al., 1992).

3D orthogonal woven fabrics at various sectional shapes as T, I and box beams were fabricated by modified 2D weaving loom (Edgson and Temple, 1998). Fabric has \pm bias, warp and filling yarns. During weaving, \pm bias fibers were placed at web of the T shape. Flange section has warp and filling and connected part of the \pm bias fibers. The process is realized on a traditional two rapier insertion loom. \pm Bias fibers' sets were placed to the web by jacquard head. \pm Bias yarns were connected during weaving of the flange section.

A laminated structure in which biaxial fabric was used as basic reinforcing elements has been developed (Homma and Nishimura, 1992). The fabric was oriented at $\pm 45^\circ$ in the web section with low dense warp layers, whereas fabric orientation 0° means warp direction in the flange with high dense warp layers. Plies were formed above the arrangement to produce I-beam in use as structural elements of aircrafts fuselage.

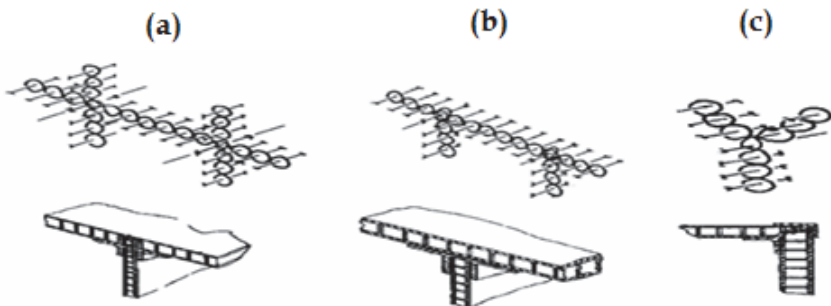

Fig. 12. 2D shaped woven connectors as H-shape (a), TT-shape (b) and Y-shape (c) (Abildskow, 1996).

A 2D woven plain fabric base laminated connector was developed. It was joined adhesively to the spar and sandwiched panel at the aircraft wing (Jonas, 1987). Integrated 2D shaped woven connector fabric was developed to join the sandwiched structures together for aircraft applications (Abildskow, 1996). The 2D integrated woven connector has warp and filling yarns. Basically, two yarn sets are interlaced at each other. Z-fibers can be used based on connector thickness. The connector can be woven as Π , Y, H shapes according to joining types as shown in Figure 12. Rib or spars as the form of sandwiched structures are joined by connector with gluing.

3.4 Multiaxis 3D fabric

Multiaxis 3D woven fabric, method and machine based on lappet weaving principles were introduced by Ruzand and Guenet (1994). Fabric has four yarn sets: \pm bias, warp and filling as shown in Figure 13. The bias yarns run across the full width of the fabric in two opposing layers on the top and bottom surfaces of the fabric, or if required on only one surface. They are held in position using selected weft yarns interlaced with warp binding yarns on the two surfaces of the structure. The intermediate layers between the two surfaces are composed of other warp and weft yarns which may be interlaced.

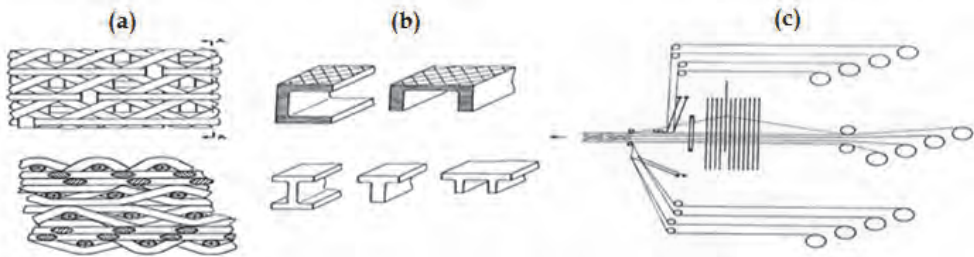

Fig. 13. Multiaxis 3D woven fabric (a), structural parts (b) and loom based on lappet weaving (c) (Ruzand and Guenet, 1994).

The basis of the technique is an extension of lappet weaving in which pairs of lappet bars are used on one or both sides of the fabric. The lappet bars are re-segmented and longer greater than the fabric width by one segment length. Each pair of lappet bars move in opposite directions with no reversal in the motion of a segment until they fully exceeds the opposite fabric selvedge. When the lappet passes across the fabric width, the segment in the lappet bar is detached, its yarns are gripped between the selvedge and the guides and it is cut near the selvedge. The detached segment is then transferred to the opposite side of the fabric where it is reattached to the lappet bar and its yarn subsequently connected to the fabric selvedge. Since a rapier is used for weft insertion, the bias yarns can be consolidated into the selvedge by an appropriate selvedge-forming device employed for weaving. The bias warp supply for each lappet bar segment is independent and does not interfere with the yarns from other segments.

A four layers multiaxis 3D woven fabric was developed (Mood, 1996). That fabric has four yarn sets: \pm bias, warp and filling. The \pm bias sets are placed between the warp (0°) and filling (90°) yarn sets so that they are locked by the warp and filling, where warp and filling yarns are orthogonally positioned as shown in Figure 14. The bias yarns are positioned by the use of special split-reeds together and a jacquard shedding mechanism with special heddles. A

creel supplies bias warp yarns in a sheet to the special heddles connected to the jacquard head. The bias yarns then pass through the split-reed system which includes an open upper reed and an open lower reed together with guides positioned in the reed dents. The lower reed is fixed while the upper reed can be moved in the weft direction.

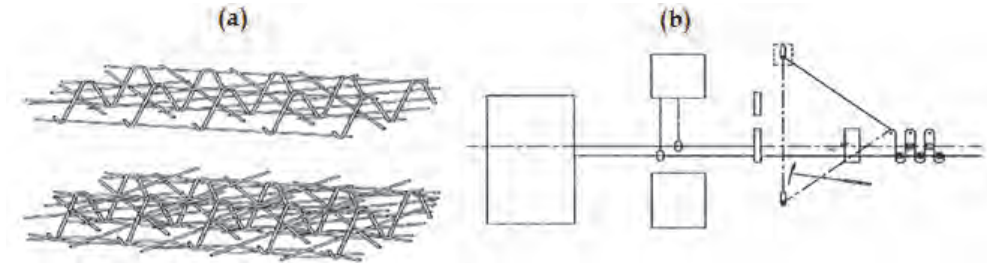

Fig. 14. Four layers multiaxis woven fabric (a) and Jacquard weaving loom (b) (Mood, 1996).

The jacquard head is used for the positioning of selected bias yarns in the dents of the upper reed so that they can be shifted transverse to the normal warp direction. The correct positioning of the bias yarns requires a series of such lifts and transverse displacements and no entanglement of the warp. A shed is formed by the warp binding yarn via a needle bar system and the weft is inserted at the weft insertion station with beat-up performed by another open reed.

Another multiaxis four layer fabric was developed based on multilayer narrow weaving principle (Bryn et al., 2004). The fabric, which has \pm bias, warp and filling yarn sets, is shown in Figure 15. The fabric was produced in various cross-sections like \perp , π , \square . Two sets of bias yarns were used during weaving and when +bias yarns were reached the selvedge of the fabric then transverse to the opposite side of the fabric and become -bias. All yarns were interlaced based on traditional plain weave.

A narrow weaving loom was modified to produce the four layers multiaxis fabric. The basic modified part is bias insertion assembly. Bias yarn set was inserted by individual hook. The basic limitation is the continuous manufacturing of the fabric. It is restricted by the bias yarn length. Such structure may be utilized as connector to the structural elements of aircraft components.



Fig. 15. Four layers multiaxis woven fabric (a) and narrow weaving loom (b) (Bryn et al., 2004).

A multiaxis weaving loom was developed to produce four layers fabric which has \pm bias, warp and filling yarns as shown in Figure 16. The process has warp creel, shuttle for filling insertion, braider carrier for +bias or -bias yarns, open reed and take-up. Bias carriers were moved on predetermined path based on cross-sectional shape of the fabric. Filling is inserted by shuttle to interlace with warp as it is same in the traditional weaving. Open reed beats the inserted filling to the fabric fell line to provide structural integrity (Nayfeh et al., 2006).

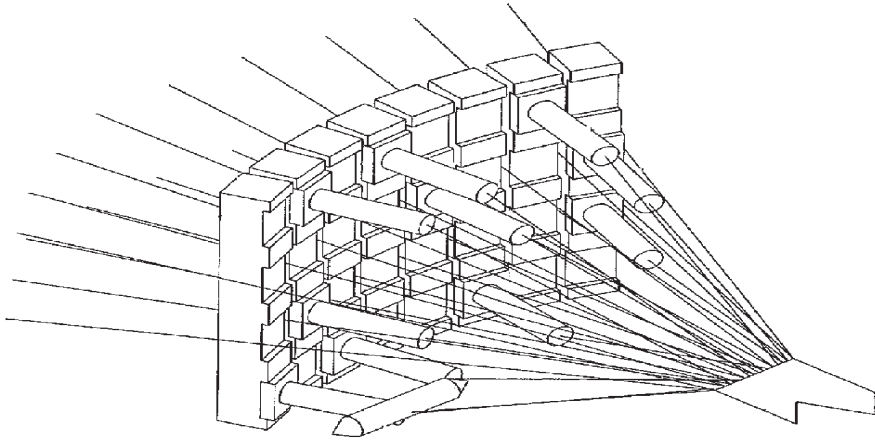

Fig. 16. Schematic view of multiaxis weaving loom (Nayfeh et al., 2006).

A multiaxis structure and process have been developed to produce the fabrics. The pultruded rods are arranged in hexagonal array as warp yarns as shown in Figure 17. Three sets of rods are inserted to the cross-section of such array at an angle about 60° . The properties of the structure may distribute isotropically depending upon end-use (Kimbara et al., 1991).

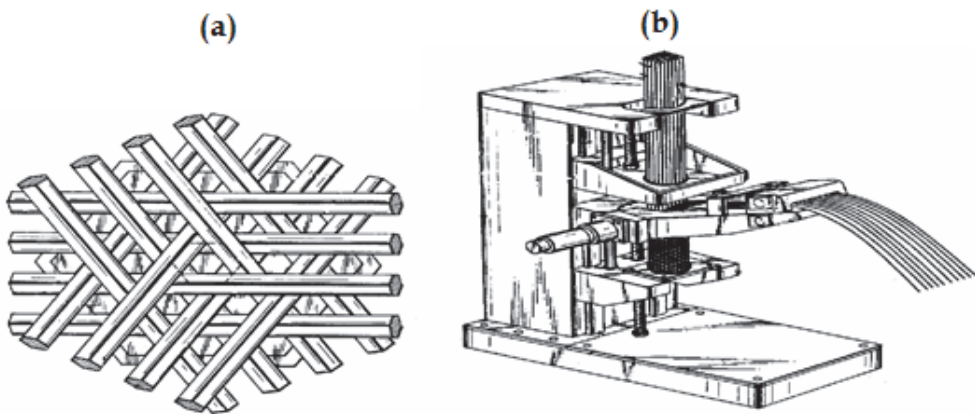

Fig. 17. Multiaxis pultruded rod fabric (a) and devise to produce the fabric (b) (Kimbara et al., 1991).

A fabric has been developed where \pm bias yarns are inserted to the traditional 3D lattice fabric's cross-section at an angle of $\pm 45^\circ$ (Khokar, 2002b). The fabric has warp, filling, Z-yarn which are orthogonal arrangements and plain type interlaced fiber sets were used as (Z-yarn)-interlace and filling-interlace as shown in Figure 18. The \pm bias yarns are inserted to such structure cross-section at $\pm 45^\circ$. The fabric has complex internal geometry and production of such structure may not be feasible.

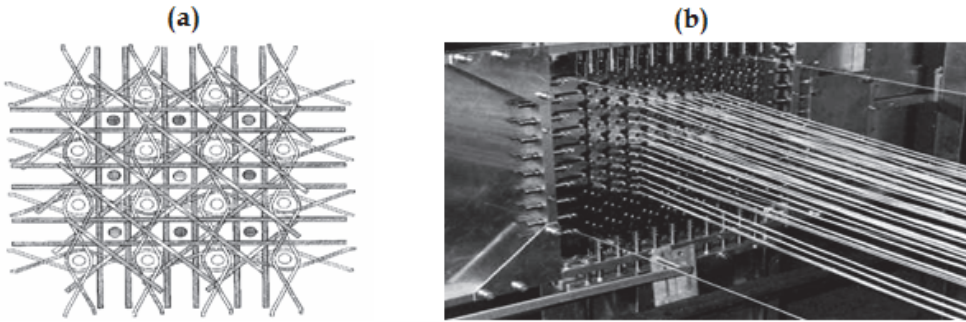

Fig. 18. The fabric (a) and specially designed loom to fabricate the multiaxis 3D fabric (b) (Khokar, 2002b).

Anahara and Yasui (1992) developed a multiaxis 3D woven fabric. In this fabric, the normal warp, bias and weft yarns are held in place by vertical binder yarns. The weft is inserted as double picks using a rapier needle which also performs beat-up. The weft insertion requires the normal warp and bias layers to form a shed via shafts which do not use heddles but rather have horizontal guide rods to maintain the vertical separation of these layers. The binders are introduced simultaneously across the fabric width by a vertical guide bar assembly comprising a number of pipes with each pipe controlling one binder as shown in Figure 19.

The bias yarns are continuous throughout the fabric length and traverse the fabric width from one selvedge to the other in a cross-laid structure. Lateral positioning and cross-laying of the bias yarns are achieved through use of an indexing screw-shaft system. As the bias yarns are folded downwards at the end of their traverse, there is no need to rotate the bias yarn supply. So, the bias yarns can supply on warp beams or from a warp creel, but they must be appropriately tensioned due to path length differences at any instant of weaving. The bias yarn placement mechanism has been modified instead of using an indexing screw shaft system, actuated guide blocks are used to place the bias yarns as shown in Figure 20.

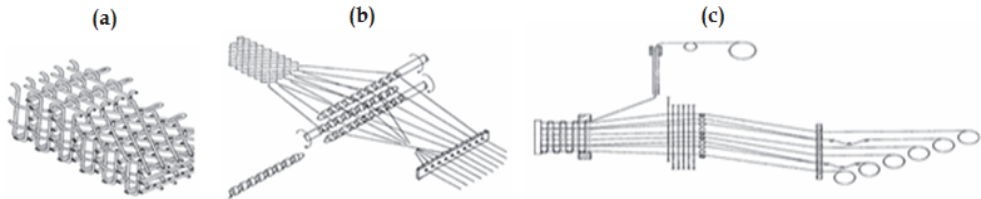

Fig. 19. The multiaxis 3D woven fabric (a), indexing mechanism for \pm bias (b) and loom (c) (Anahara and Yasui, 1992).

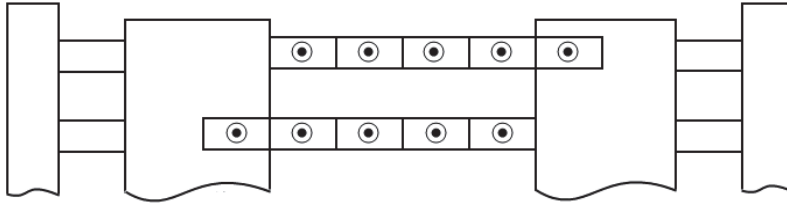

Fig. 20. Guide block mechanism for \pm bias yarns (Anahara and Yasui, 1992).

A folded structure of the bias yarns results in each layer having triangular sections which alternate in the direction of the bias angle about the warp direction due to the bias yarn interchanges between adjacent layers. The bias yarns are threaded through individual guide blocks which are controlled by a special shaft to circulate in one direction around a rectangular path. Obviously, this requires rotation of the bias yarn supply.

Uchida et al. (1999) developed the fabric called five-axis 3D woven which has five yarn sets: \pm bias, filling and warp and Z-fiber. The fabric has four layers and sequences: +bias, -bias, warp and filling from top to bottom. All layers are locked by the Z-fibers as shown in Figure 21.

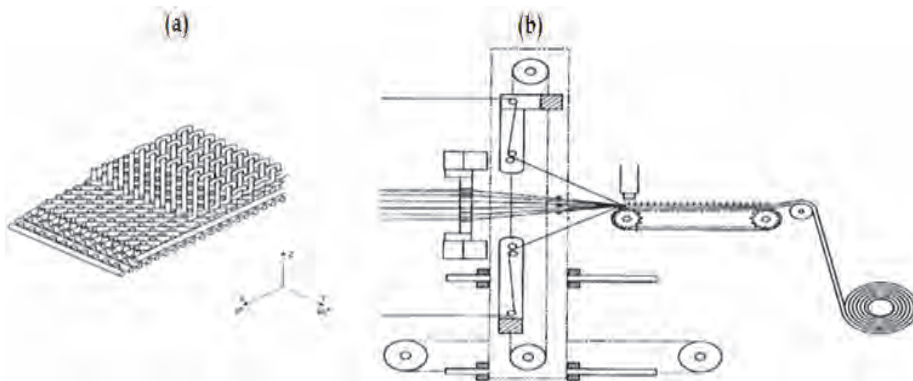

Fig. 21. Five-axis fabric (a) and newly developed weaving loom (b) (Uchida et al., 1999).

The process has bias rotating unit, filling insertion, Z-yarn insertion, warp, \pm bias and Z-fiber feeding units, and take-up. A horizontally positioned bias chain rotates one bias yarn distance to orient the yarns, and filling is inserted to the fixed shed. Then Z-yarn rapier inserts the Z-yarn to bind all yarns together and all Z-yarn units are moved to the fabric fell line to carry out the beat-up function. The take-up removes the fabric from the weaving zone.

Mohamed and Bilisik (1995) developed multiaxis 3D woven fabric, method and machine in which the fabric has five yarn sets: \pm bias, warp, filling and Z-fiber. Many warp layers are positioned at the middle of the structure. The \pm bias yarns are positioned on the back and front faces of the preform and locked the other set of yarns by the Z-yarns as shown in Figure 22. This structure can enhance the in-plane properties of the resulting composites.

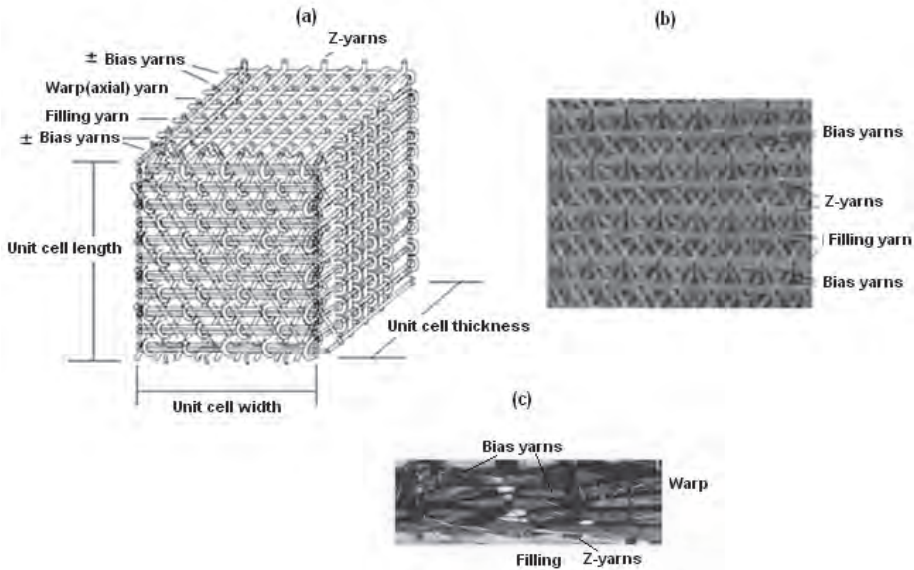

Fig. 22. The unit cell of multiaxis fabric (a), top surface of multiaxis small tow size carbon fabric (b) and cross-section of the multiaxis carbon fabric (c) (Mohamed and Bilisik, 1995; Bilisik, 2010a).

The warp yarns are arranged in a matrix of rows and columns within the required cross-sectional shape. After the front and back pairs of the bias layers are oriented relative to each other by the pair of tube rapiers, the filling yarns are inserted by needles between the rows of warp (axial) yarns and the loops of the filling yarns are secured by the selvage yarn at the opposite side of the preform by selvage needles and cooperating latch needles. Then, they return to their initial position as shown in Figure 23. The Z-yarn needles are inserted to both front and back surface of the preform and pass across each other between the columns of the warp yarns to lay the Z-yarns in place across the previously inserted filling yarns. The filling

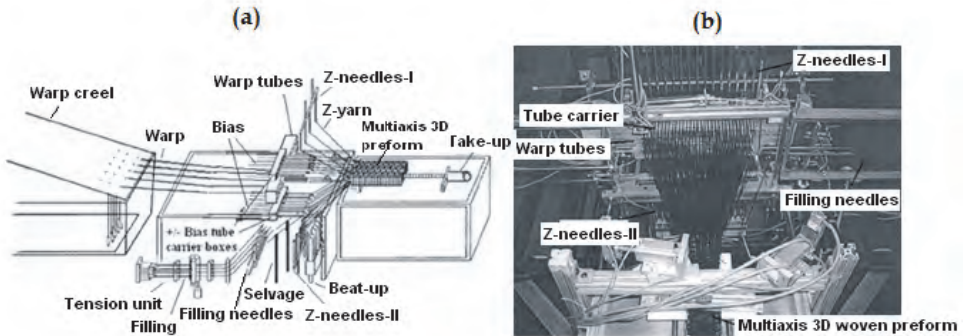

Fig. 23. Schematic view of multiaxis weaving machine (a) and top side view of multiaxis weaving machine (b) (Mohamed and Bilisik, 1995; Bilisik, 2010b).

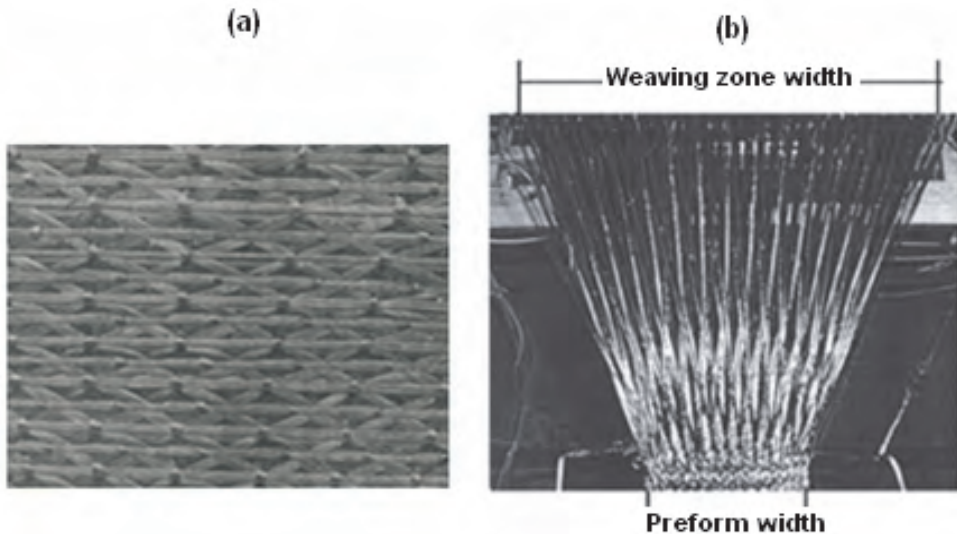

Fig. 24. Top surface of multiaxis large tow size carbon fabric (a) and weaving zone of the multiaxis weaving machine (b) (Bilisik, 2009a).

is again inserted by filling insertion needles and secured by the selvage needle at the opposite side of the preform. Then, the filling insertion needles return to their starting position. After this, the Z-yarns are returned to their starting position by the Z-yarn insertion needles by passing between the columns of the warp yarns once again and locking the bias yarn and filling yarns into place in the woven preform. The inserted filling, \pm bias and Z-yarns are beaten into place against the woven line as shown in Figure 24, and a take-up system moves the woven preform.

Bilisik (2000) developed multiaxis 3D circular woven fabric, method and machine. The preform is basically composed of the multiple axial and radial yarns, multiple circumferential and the \pm bias layers as shown in Figure 25. The axial yarns (warp) are arranged in a radial rows and circumferential layers within the required cross-sectional shape. The \pm bias yarns are placed at the outside and inside ring of the cylinder surface. The filling (circumferential) yarns lay the between each warp yarn helical corridors. The radial yarns (Z-fiber) locks the all yarn sets to form the cylindrical 3D preform. A cylindrical preform can be made thin and thick wall section depending upon end-use requirements.

A process has been designed based on the 3D braiding principle. It has machine bed, \pm bias and filling ring carrier, radial braider, warp creel and take-up. After the bias yarns are oriented at $\pm 45^\circ$ to each other by the circular shedding means on the surface of the preform, the carriers rotate around the adjacent axial layers to wind the circumferential yarns. The radial yarns are inserted to each other by the special carrier units and locked the circumferential yarn layers with the \pm bias and axial layers all together. A take-up system removes the structure from the weaving zone. This describes one cycle of the operation to weave the multiaxis 3D circular woven preform. It is expected that the torsional properties of the preform could be improved because of the bias yarn layers.

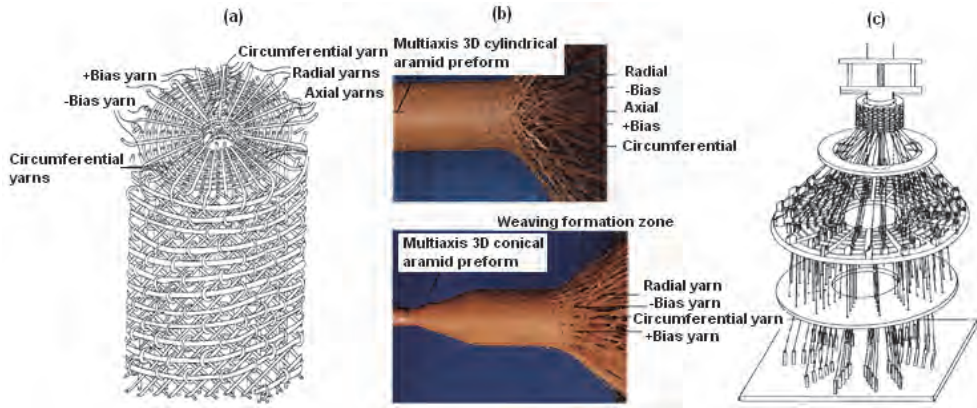

Fig. 25. The unit cell of multiaxis 3D circular woven fabric (a), Multiaxis 3D aramid circular woven fabric (b) and the weaving loom (c) (Bilisik, 2000; Bilisik, 2010c).

3.5 Multiaxis 3D knitted fabric

Wilkens (1985) introduced a multiaxis warp knit fabric for Karl Mayer Textilmaschinenfabrik GmbH. The multiaxis warp knit machine which produces multiaxis warp knit fabric has been developed by Naumann and Wilkens (1987). The fabric has warp (0° yarn), filling (90° yarn), ±bias yarns and stitching yarns as shown in Figure 26. The machine includes ±bias beam, ±bias shifting unit, warp beam feeding unit, filling laying-in unit and stitching unit. After the bias yarn rotates one bias yarn distance to orient the fibers, the filling lays-in the predetermined movable magazine to feed the filling in the knitting zone. Then the warp ends are fed to the knitting zone and the stitching needle locks the all yarn sets to form the fabric. To eliminate the bias yarn inclination in the feeding system, machine bed rotates around the fabric. The stitching pattern, means tricot or chain, can be arranged for the end-use requirements.

Hutson (1985) developed a fabric which is similar to the multiaxis knitted fabric. The fabric has three sets of yarns: ±bias and filling (90° yarn) and the stitching yarns lock all the yarn sets to provide structural integrity. The process basically includes machine track, lay down fiber carrier, stitching unit, fiber feeding and take-up. The +bias, filling and -bias are laid according to yarn layer sequence in the fabric. The pinned track delivers the layers to the stitching zone. A compound needle locks the all yarn layers to form the fabric.

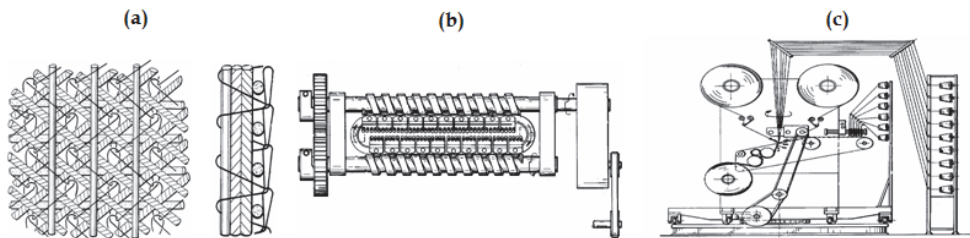

Fig. 26. Top and side views of multiaxis warp knit fabric (a) (Wilkens, 1985), bias indexing mechanism (b), warp knitting machine (c) (Naumann and Wilkens, 1987).

Wunner (1989) developed the machine produces the fabric called multiaxis warp knit for Liba GmbH. It has four yarn sets: \pm bias, warp and filling (90° yarn) and stitching yarn. All layers are locked by the stitching yarn in which tricot pattern is used as shown in Figure 27. The process includes pinned conveyor bed, fiber carrier for each yarn sets, stitching unit, yarn creels and take-up.

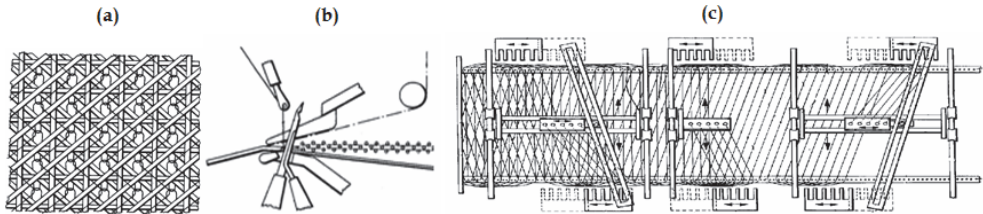

Fig. 27. Warp knit structure (a), stitching unit (b) and warp knit machine (c) (Wunner, 1989).

A multiaxis warp knit/braided/stitching type structure for aircraft wing-box has been developed by NASA/BOEING. The multiaxis warp knit fabric is sequence and cuts from 2 to 20 layers to produce a complex aircraft wing skin structure. Then, a triaxial braided tube is collapsed to produce a stiffener spar. All of them are stitched by the multi-head stitching machine which was developed by Advanced Composite Technology Programs. The stitching density is 3 columns/cm. The complex contour shape can be stitched according to requirements as shown in Figure 28. When the carbon dry preform is ready, resin film infusion technique is used to produce the rigid composites. In this way, 25 % weight reduction and 20 % cost savings can be achieved for aircraft structural parts. In addition, the structures have high damage tolerance properties (Dow and Dexter, 1997).

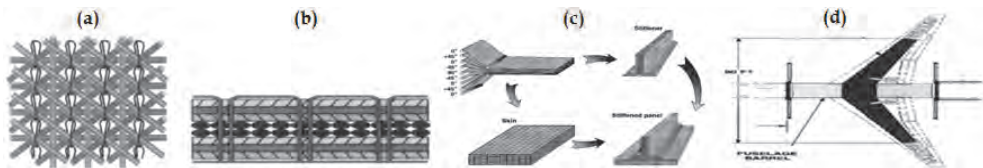

Fig. 28. Warp knit structure (a), multilayer stitched warp knit structure (b), layering-stitching-shaping (c) and application in airplane wing structure (d) (Dow and Dexter, 1997).

3.6 Comparison of fabric and methods

Kamiya et al. (2000) compared the multiaxis 3D woven fabrics and methods based on the bias fiber placement and uniformity, the number of layers and through-the-thickness (Z-yarn) reinforcements. It is concluded that the biaxial fabric/stitching, and the multiaxis knitted fabric and methods are readily available. It is recommended that multiaxis 3D woven fabrics and methods must be developed further. More general comparison is carried out and presented in Table 2. As seen in Table, multiaxis 3D fabric parameters are the yarn sets, interlacement, yarn directions, multiple layer and fiber volume fraction. The multiaxis 3D weaving process parameters are the bias unit, manufacturing type as continuous or part, yarn insertion, packing and development stage. It is realized that the triaxial fabrics and 3D woven fabrics are well developed and they are commercially available. But multiaxis 3D woven fabric is still early stage of its development.

Fabric	Yarn sets	Interlacement	Yarn directions	Multiple layer	Fiber volume fraction	Development Stage
Ruzand and Guenot, 1994	Four	Interlace, plain	Warp/weft/ \pm Bias In-plane	Four layers	Low or Medium	Commercial stage
Anahara and Yasui, 1992 Uchide et al., 2000	Five	Non-interlace	Warp/Weft/ \pm Bias /Z-yarn In-plane	More than four layers	Low	Prototype stage
Mohamed and Bilisik, 1995	Five	Non-interlace	Warp/Weft/ \pm Bias /Z-yarn In-plane	More than four layers	Medium or High	Prototype stage
Khokar, 2002b	Five	Interlace, plain	Warp/Weft/ \pm Bias /Z-yarn Out-of-plane	More than four layers	Low or Medium	Prototype stage
Bryn et al., 2004 Nayfeh et al., 2006	Four	Interlace, plain	Warp/Weft/ \pm Bias In-plane	Four layers	Low or Medium	Prototype stage
Yasui et al., 1992	Four	Non-interlace	Axial/Circumferential + or - Bias	Five layers	Medium	Prototype stage
Bilisik, 2000	Five	Non-interlace	Axial/Circumferential/ \pm Bias/Z-yarn	More than four layers	High	Early Prototype stage
Wilkins, 1985	Four	Non-interlace	Warp/Weft/ \pm Bias /Stitched yarn	Four layers	Medium or High	Commercial stage
Wunner, 1989	Four	Non-interlace	Warp/Weft/ \pm Bias /Stitched yarn	Four layers	Medium or High	Commercial stage

Table 2. Comparison of the multiaxis 3D fabrics and methods.

4. Multiaxis fabric properties and composites

4.1 Triaxial fabric

Scardino and Ko (1981) reported that the fabric has better properties to the bias directions compared to the biaxial fabric which has warp (0° yarn) and filling (90° yarn) to interlace each other at principal directions. Comparisons have revealed a 4-fold tearing strength and 5-fold abrasion resistance compared with a biaxial fabric with the same setting. Elongation and strength properties are roughly the same. Schwartz (1981) analyzed the triaxial fabrics

and compared with the leno and biaxial fabrics. He defined the triaxial unit cell and proposed the fabric moduli at crimp removal stage. It is concluded that the equivalency in all fabrics must be carefully defined to explore usefulness of the triaxial fabric. Schwartz (1981) suggested that when the equivalence is determined, triaxial fabric has better isotropy compare to the leno and plain fabrics. Isotropy can be considered on the fabric bursting and tearing strengths, shearing and bending properties. Skelton (1971) proposed the bending rigidity relations depending upon the angle of orientation. Triaxial fabric is independent of the orientation angle for bending. It is isotropic. Skelton (1971) noted that the 3-ply, 95 tex nylon and graphite yarns are used to do the comparable triaxial and biaxial fabrics. The stability of the triaxial fabric is much greater than that of an orthogonal fabric with the same percent open area. The triaxial fabric exhibits greater isotropy in its bending behavior and a greater shear resistance than a comparable orthogonal fabric.

4.2 General properties of 3D fabrics

The 3D woven fabrics are designed for composite structural component for various applications where structural design depends on loading conditions. Their basic parameters are fiber and matrix properties; total and directional volume fraction; preform types; yarn orientation in the preform and preform geometry. These parameters together with end-use requirements determine the preform manufacturing techniques. Many calculation techniques have also been developed by the aid of computer supported numerical methods in order to predict the stiffness and strength properties and understand the complex failure mechanism of the textile structural composite (Chou, 1992).

4.3 Multiaxis 3D and 3D orthogonal fabric process-property relations

Gu (1994) reported that the take-up rate of the 3D weaving effects the directional and total volume fraction of 3D woven fabrics. A high packing density can be achieved if the beat-up acts twice to the fabric formation line. Friction between brittle fiber such as carbon and parts of weaving machine must be kept low to prevent the filament breakages. Bilisik (2009a) identified the most related process-product parameters. These are the bias angle, width ratio, packing, tension and fiber waviness. The bias angle is the angle between bias fiber and warp fiber to the machine direction. The bias fiber is oriented by discrete tube-block movement. One tube-block movement is about 15° – 22° based on the process parameters. If it requires any angle between 15° and 75° , the tube-block must be moved by one, two, or three tube distance. A small angle changes have been identified from the loom state to the out-of-loom state at an average of 46° to 42° .

The multiaxis weaving width is not equal to that of the preform as shown in Figure 24. This difference is defined as the width ratio (preform width/weaving width). This is not currently the case in the 2D or 3D orthogonal weaving. The width ratio is almost 1/3 for multiaxis weaving. This is caused by an excessive filling length during insertion. It is reported that the fiber density and pick variations are observed. Some of the warp yarns accumulated at the edges are similar to those of the middle section of the preform. When the preform cross-section is examined, a uniform yarn distribution is not achieved for all the preform volume as shown in Figure 22. These indicate that the light beat-up did not apply enough pressure to the preform, and the layered warp yarns are redistributed under the initial tension. In part, the crossing of bias yarn prevents the Z-yarn from sliding the filling yarns towards the fabric line where the filling is curved. Probably, this problem is unique to

multiaxis weaving. Hence, it can be concluded that the rigid beat-up is necessary. This unique problem can be solved by a special type of open reed, if the width ratio is considered the main design parameter (Bilisik, 2010d). Dry volume fraction in the fabricated preform shows that increasing the fiber content in the warp or \pm bias and filling fiber sets results in a high total preform volume fraction and porosity in the crossing points of fiber sets in the preform is reduced (Bilisik, 2009a).

Fiber waviness is observed during weaving at the bias and filling yarn sets. The bias yarn sets do not properly compensate for excessive length during biasing on the bias yarns. Variable tensioning may be required for each bias bobbin. The filling yarn sets are mainly related to the width ratio and level of tension applied. A sophisticated tensioning device may be required for filling yarn sets. On the other hand, the brittle carbon fiber characteristics must be considered. The bias fiber waviness is observed during weaving in the loom state. First of all, this is because of the variable tension in the bias fiber sets. Secondly, other fiber sets affect the bias waviness in the fabric formation zone. Thirdly, because of the rotatable creel used for the \pm bias fiber sets, there is an excessive bias fiber on the preform surface. This causes the \pm bias waviness, and it is eliminated by the compensation system connected to the rotational bias creels. The filling waviness mainly depends on the width ratio, and the related processing parameter is the selvage transfer system. The Z-fiber waviness depends on the Z-fiber path which is different during the half cycle of the weaving and another half cycle. This is because Z-fiber needles, means, open needle shed and it is a part of the processing parameter.

The parameters related with the multiaxis 3D circular woven fabric-process are bias orientation, radial and circumferential yarn insertion, beat-up and take-up. It is found out that the bias yarns are on the outer and inner surfaces of the structure form helical paths and there is a slight angle difference between them especially producing the thick wall preforms. There is a certain relation between preform density (fiber volume fraction), bias yarn orientation and take-up rate. More researches may be required to understand the relations between those processing parameters and preform structural parameters. In circumferential yarn insertion, the excessive yarn length during circumferential yarn insertion occurs due to diameter ratio (preform outer diameter/outermost ring diameter) which is not 1. The amount of the diameter ratio depends on the number of the rings. When the excessive circumferential yarn is not retracted, this causes waviness in the structure. However, there must be adequate tension applied on the circumferential yarns to get proper packing during beat-up. The circumferential yarn ends in each layer, which are equivalent to filling in the flat weaving, are six during insertion. This is resulted in high insertion rate. It is realized that there is a relation between the number of layers and radial yarn retraction. If the number of layers in the preform increases, yarn retraction in the radial carrier increases. The retraction must be kept within the capacity of the radial carrier. It is also observed that the tension level in the radial yarn is kept high compared to that of the circumferential yarns because of easy packing and applying tensioning force to the bias crossing points which resists the radial yarn movements during structure formation at the weaving zone. However, there is a certain relation between radial yarn tension and beat-up force. There must be an optimum tension level and beat-up force between them during the weaving for proper structural formation. It is observed that the radial yarn in the structure is at a slight angle. This depends partly on the structure wall thickness and partly on the weaving zone length during structure formation. In this point, the take-up rate is a crucially important process parameter. Also, a high beat-up force causes local yarn distortion in the structure. It

is understood that the beat-up unit in the experimental loom must be modified to get consistent volume fraction, especially when the brittle fibers are used. It is understood that two types of take-up are necessary. A part manufacturing needs mandrel and is adapted to the take-up unit. A continuous manufacturing needs a pair of coated cylinders. For both take-up units, the important process parameter is take-up rate during delivering the fabric from the weaving zone. The rate affects the fabric volume fraction and the bias angle, and relations between preform structural parameters and processing parameters must be analyzed. This is addressed for future analytical research in take-up rate (Bilisik, 2010c).

4.4 Multiaxis 3D and 3D orthogonal fabric composites

Cox et al. (1993) stated that low volume fraction 3D woven preform may be performed well under the impact load compare to that of the tight volume fraction 3D woven preform. Dickinson (1990) studied on 3D carbon/epoxy composites. It is realized that the amount of Z-yarn and the placement of Z-yarn in the 3D woven preform influence the in-plane properties of the 3D woven structure. When the Z-yarn volume ratio increases, the in-plane properties of the 3D woven structure decrease. The placement of the Z-yarn in unit cell of the 3D woven fabric decreases, failure mode of the 3D woven composite changes and a local delamination occurs. Babcock and Rose (2001) explained that under the impact load, 3D woven or 2D fabric/stitched composites confines the impact energy due to the Z-yarn.

A five-axis 3D woven fabric composite was characterized by Uchida et al. (2000). Tensile and compression results of multiaxis weave and stitched 2D laminate are comparable. Open hole tensile and compression results of multiaxis woven structure look better compared to that of the stitched 2D laminated structure. Compression After Impact (CAI) test shows that the 5-axis 3D woven composite is better than that of the stitched 2D laminated structure. Also, damaged area in terms of absorbed energy level is small at the 5-axis 3D woven composite compared to that of the stitched 2D laminated composite. The multiaxis 3D knitted fabric suffers from limitation in fiber architecture, through-thickness reinforcement due to the thermoplastic stitching thread and three dimensional shaping during molding.

For this reasons, multiaxis 3D knitted fabric is layered and stitched to increase damage resistance and to reduce production cost (Dow and Dexter, 1997).

Another experimental research was conducted on multiaxis and orthogonal 3D woven composites by Bilisik (2010d). Bending strength and modulus of the multiaxis and orthogonal woven composites were 569 and 715 MPa, and 43.5 and 50.5 GPa, respectively. Bending strength and modulus of the 3D orthogonal woven composites were higher than those of multiaxis 3D woven composites by about 20% and 14%, respectively. This indicates that the \pm bias yarn orientations on both the surfaces of multiaxis woven composite cause a reduction in bending properties. Bending failure in the multiaxis 3D woven composite is shown in Figure 29, where there is a bias yarn breakage at the outside surface of the warp side and a local delamination is seen between the filling and \pm bias yarns in places where it is restricted by Z-yarn. In the 3D orthogonal woven composite, bending failure occurs at the outside surface of the structure. Initially, matrix and yarn breakages are in normal direction of yarn but later on these breakages turns and propagates in parallel to the yarn direction. Crack propagation is restricted by Z-yarn.

Interlaminar shear strengths were determined as 47.1 MPa for multiaxis woven composite and as 52.2 MPa for orthogonal woven composite. Interlaminar shear strength of the 3D orthogonal woven composite was higher than that of multiaxis 3D woven composites

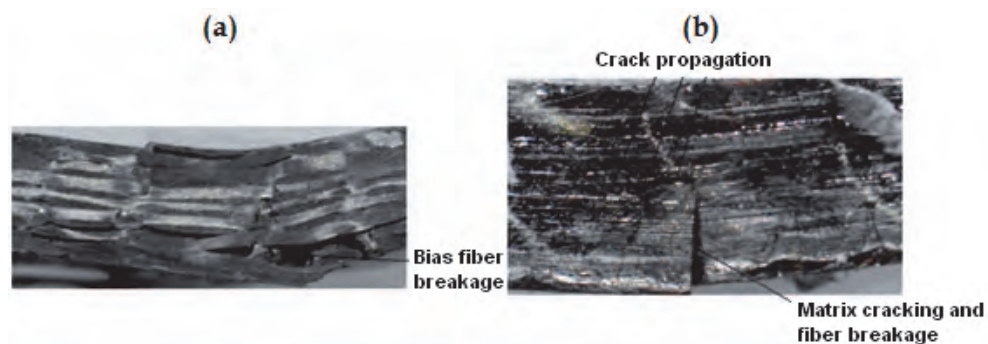

Fig. 29. Bending failure on the warp side of the multiaxis 3D woven composite (a) and bending failure on the warp side of the 3D orthogonal woven composite (b). Magnifications: $\times 6.7$ (a), $\times 18$ (b) (Bilisik, 2010d).

almost by 10%. The \pm bias yarns have no considerable effect on interlaminar shear strength of the multiaxis 3D woven composite. There is a shear on directional yarn breakages mainly at bias and warp yarns and some local yarn–matrix splitting on the warp side of the structure. On the surface, local yarn crack occurs throughout the normal direction of the warp yarn. In the 3D orthogonal woven composite, yarn and matrix cracks are observed at the shearing load on warp side and filling yarn direction of the surface of the structure as shown in Figure 30.

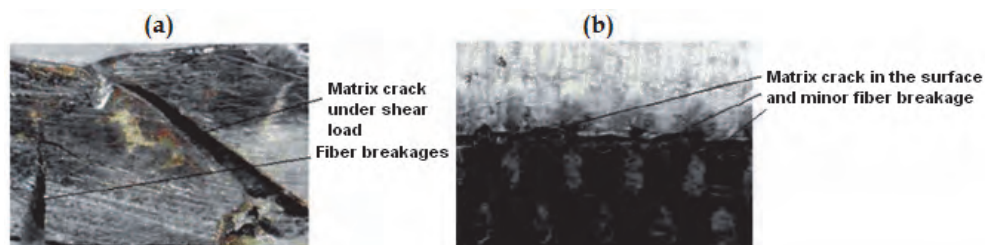

Fig. 30. Interlaminar shear failure on the warp side (a) and on the outside surface (b) of 3D woven composite. Magnifications: $\times 20$ (a), $\times 6.7$ (b) (Bilisik, 2010d).

In-plane shear strength and modulus of the multiaxis and orthogonal woven composites were measured as 137.7 and 110.9 MPa, and 12.1 and 4.5 GPa, respectively. In-plane shear strength and modulus of the multiaxis 3D woven composites were higher than those of multiaxis 3D woven composites almost by 25% for in-plane shear strength and 170% for in-plane shear modulus due to the addition of the \pm bias yarns on the surface of the multiaxis 3D woven composites. There is a local delamination on the warp-filling yarns and local breakages on \pm bias yarns through-the-thickness direction and surface of the multiaxis 3D woven composites for in-plane shear failure as seen in Figure 31. For 3D orthogonal woven composite, there is a local yarn breakage between the warp and filling yarns and a local delamination between the warp and filling yarns through-the-thickness direction.

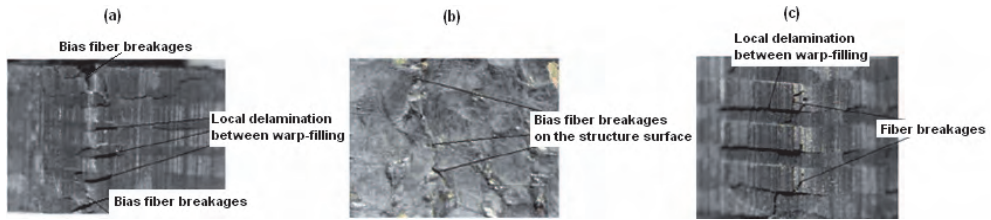

Fig. 31. In-plane shear failure (a), in-plane shear failure at surface (b) of the multi-axis 3D woven composite and in-plane shear failure (c) of the 3D orthogonal woven composite. Magnifications: $\times 13$ (a), $\times 6.7$ (b), $\times 18$ (c) (Bilisik, 2010d).

		Carbon Fiber		Epoxy Matrix
		Thornel™ PAN	T-300	(Tactix™ 123) ³
Material Properties	Tensile Strength (MPa)	3450		76.50
	Tensile Modulus (GPa)	230		3.45
	Modulus of Rigidity (GPa)	88.50		1.30
	Elongation (%)	1.62		5.70
	Poisson's ratio (ν)	0.27		0.31
	Density (g/cm ³)	1.76		1.16
		Preform 1		Preform 2
Bias angle (°), (measured)		30°		40°
Fractional volume (%), (measured at preform)	+Bias	9.43		11.7
	-Bias	9.43		11.7
	Warp	10.5		13.7
	Filling	5.42		4.77
	Z-yarn	3.67		5.61
	Total Volume (%)	38.4		47.5
Elastic constants (Calculated)	Modulus of elasticity (GPa)	E ₁₁	48.33	48.00
		E ₂₂	19.87	23.85
		E ₃₃	9.86	14.24
	Modulus rigidity (GPa)	G ₁₂	10.42	15.65
		G ₂₃	2.78	3.47
		G ₃₁	2.80	3.47
	Poisson's ratio	ν_{12}	0.446	0.530

Table 3. Multi-axis 3D woven preform elastic constants from multi-axis 3D weaving (Bilisik & Mohamed, 2010).

Gowayed and Pastore (1992) reviewed on computation methods for 3D woven fabric. The developed analytical methods are stiffness averaging, fabric geometry and inclination models. They are based on the classical lamination theory, and micro mechanic approach is considered. Bilisik & Mohamed (2010) applied stiffness averaging method to multi-axis 3D

carbon/epoxy composites. Table 3 shows the directional tensile and shear elastic constants of multiaxis carbon/epoxy composite structure. It is demonstrated that yarn orientation in the preform influences the shearing properties of the multiaxis 3D woven composite structure.

4.5 Applications

Traditional as well as contemporary fabric structures are increasingly gaining acceptance due to their attractive specific performances and low cost in use for the technical textiles (Hearle, 1994) such as defense and civilian areas as transportation, automobile, energy and marine industries (Mouritz et al., 1999). Biaxial, triaxial and more sophisticated multiaxis 3D fabric structures are used as structural elements in medical, space and rocket propulsions (Beyer et al., 2006). Examples of these elements are plate, stiffened panel and beams and spars, shell or skin structures (Yamamoto and Hirokawa, 1990), hip and medical devices and prosthesis (Donnet and Bansal, 1990; Bilisik, 2009b). Recently, Atkinson et al., (2008) explored that using the nano based high modulus fibers in 3D fabrics results 10-fold increase of their mechanical properties.

5. Conclusion

3D fabrics, methods and techniques have been reviewed. Biaxial 2D fabrics have been widely used as structural composite parts in various technical areas. However, composite structures of biaxial 2D fabrics have delamination between layers due to the lack of fibers. Biaxial methods and techniques are well developed. Triaxial fabrics have delamination, open structure and low fabric volume fractions. But, in-plane properties of the triaxial fabrics become homogeneous due to the \pm bias yarn orientations. Triaxial weaving methods and techniques are also well developed. 3D woven fabrics have multiple layers and no delamination due to the Z-fibers. But, the 3D woven fabrics have low in-plane properties. 3D weaving methods and techniques are commercially available. Multiaxis 3D knitted fabrics which have four layers and layering is fulfilled by stitching, have no delamination and in-plane properties are enhanced due to the \pm bias yarn layers. But, it has a limitation for multiple layering and layer sequences. Multiaxis 3D knitting methods and techniques have been perfected. Multiaxis 3D woven fabrics have multiple layers and no delamination due to the Z-fibers and in-plane properties enhanced due to the \pm bias yarn layers. Also, layer sequence can be arranged based on the requirements. But, multiaxis 3D weaving technique is at its early development stages and needs to be fully automated. This will be the future technological challenge in this area.

6. Acknowledgements

The author thanks the Research Assistant Gaye Yolacan for her help during the preparation of this book chapter.

7. References

- Abildskow, D. (1996). *Three dimensional woven fabric connector*, US Patent 5533693.
- Anahara, M. & Yasui, Y. (1992). *Three dimensional fabric and method for producing the same*, US Patent 5137058.

- Atkinson, K. R., Skourtis, C. & Hutton, S. R. (2008). Properties and applications of dry-spun carbon nanotube yarns, *Advances in Science and Technology*, 60: 11-20.
- Babcock, W. & Rose, D. (2001). Composite preforms, *The AMPTIAC Newsletter*, 5(1): 7-11.
- Beyer, S., Schmidh, S., Maida, F., Meistring, R., Bouchez, M. & Peres, P. (2006). Advanced composite materials for current and future propulsion and industrial applications, *Advances in Science and Technology*, 50: 178-171.
- Bilisik, A. & Mohamed M. H. (1994). Multiaxis 3D weaving machine and properties of Multiaxial 3D woven carbon/epoxy composites, *The 39th International SAMPE Symposium*, Anaheim, USA.
- Bilisik, K. (1991). *Three dimensional (3D) weaving and Braiding*, PhD Thesis, University of Leeds, Leeds, UK.
- Bilisik, K. (2000). *Multiaxial three dimensional (3D) circular woven fabric*, US Patent 6129122.
- Bilisik, K. (2009a). Multiaxis three dimensional (3D) flat woven fabric and weaving method: Feasibility of prototype Tube Carrier Weaving, *Fibres and Textiles in Eastern Europe* 17(6): 63-69.
- Bilisik, K. (2009b). Multiaxis Three-Dimensional (3-D) Woven and Braided Preform Unit Cells and Implementation of Possible Functional Characterization for Biomedical Applications, *Artificial Organs*, 33(8): A101.
- Bilisik, K. (2010a). Multiaxis 3D Weaving: Comparison of Developed Two Weaving Methods-Tube-Rapier Weaving Versus Tube-Carrier Weaving and Effects of Bias Yarn Path to the Preform Properties, *Fibers and Polymers*, 11(1): 104-114.
- Bilisik, K. (2010b). Dimensional Stability of Multiaxis 3D Woven Carbon Preform, *Journal of the Textile Institute*, 101(5): 380-388.
- Bilisik, K. (2010c). Multiaxis Three Dimensional (3D) Circular Woven Preforms-Radial Crossing Weaving and Radial In-Out Weaving: Preliminary investigation of feasibility of weaving and methods, *Journal of the Textile Institute*, 101(11): 967-987.
- Bilisik, K. (2010d). Multiaxis 3D woven preform and properties of multiaxis 3D woven and 3D orthogonal woven carbon/epoxy composites, *Journal of Reinforced Plastics and Composites*, 29(8): 1173-1186.
- Bilisik, K. & Mohamed, M. H. (2010). Multiaxis Three Dimensional (3D) Flat Woven Preform-Tube Carrier Weaving, *Textile Research Journal*, 80(8): 696-711.
- Bhatnagar, A. & Parrish, E. S. (2006). *Bidirectional and multiaxial fabric and fabric composites*, US Patent 7073538.
- Brandt J., Drechsler, K. & Filsinger, J. (2001). Advanced textile technologies for the cost effective manufacturing of high performance composites, *RTO AVT Specialist Meeting on Low Cost Composite Structures*, Norway, RTO-MP-069(II).
- Bryn, L., Islam, M. A., Lowery, W. L. & Harries, H. D. (2004). *Three-dimensional woven forms with integral bias fibers and bias weaving loom*, US Patent 6742547.
- Chen, X. (2007). *Technical aspect: 3D woven architectures*, NWTexNet 2007 Conference, Blackburn, UK.
- Chou, T. W. (1992). *Microstructural Design of Fiber Composites*, UK: Cambridge University Press.
- Cox, B. N., Dadkhah, M. S., Morris, W. L. & Flintoff, J. G. (1993). Failure mechanisms of 3D woven composites in tension, compression and bending, *ACTA Metallurgica et Materialia* 42: 3967-84.

- Cox B.N. & Flanagan, G. (1997). *Handbook of analytical methods for textile composites*, NASA Contractor Report 4750.
- Crawford, J. A. (1985). *Recent developments in multidirectional weaving*, NASA Publication No. 2420, pp. 259-269.
- Deemey, S. (2002). The new generation of carpet weaving machines combines flexibility and productivity, *Technical notes*, Van de Wiele Incorporations.
- Dexter, H. B. & Hasko G. H. (1996). Mechanical properties and damage tolerance of multi-axial warp-knit composites, *Composites Science and Technology* 51: 367-380.
- Dickinson, L. C. (1990). *Evaluation of 3D woven carbon/epoxy composites*, MSc Thesis, NCSU, USA.
- Donnet, J. B., Bansal, R. C. (1990). *Carbon Fibers*, Marcel Dekker Inc., New York, USA.
- Dow, M. B. & Dexter, H. B., (1997). *Development of stitched, braided and woven composite structures in the ACT Program and at Langley Research Center (1985 to 1997)*. NASA/TP-97-206234.
- Dow, N. F. (1969). *Triaxial fabric*, US Patent 3446251.
- Dow, N. F. & Tranfield G. (1970). Preliminary investigations of feasibility of weaving triaxial fabrics (Doweave), *Textile Research Journal* 40(11): 986-998.
- Edgson, R. & Temple, S. (1998). *Fibre preforms for structural composite components*, US Patent 5783279.
- Evans, R.G. (1999). *Air jet machine and diagonal Z loop fabric pattern for three dimensional fabrics*, US Patent 5924459.
- Fukuta, K., Nagatsuka, Y., Tsuburaya, S., Miyashita, R., Sekiguti, J., Aoki, E. & Sasahara, M. (1974). *Three dimensional fabric, and method and loom construction for the production thereof*, US Patent 3834424.
- Goldstein, A. D. (1939). *Textile material*, US Patent 2244835.
- Gowayed, Y. A. & Pastore, C. M. (1993). Analytical techniques for the prediction of elastic properties of textile reinforced composites, *Mechanics of composite materials*, 28(5): 393-408.
- Gu, P. (1994). *Analysis of 3D woven preforms and their composite properties*, PhD Thesis, NCSU, College of Textiles, Raleigh.
- Hearle, J. W. S. (1994). Textile for composites, *Textile Horizons*, 11: 11-15.
- Homma, K. & Nishimura, A. (1992). *Reinforcing woven fabric and preformed material, fiber reinforced composite material and beam using it*, US Patent 5100713.
- Hutson, H. K. (1985). *Biased multilayer structural fabric composites stitched in a vertical direction*, US Patent 4550045.
- Jonas, P.J. (1987). *Method for fastening aircraft frame elements to sandwich skin panels covering same using woven fiber connectors*, US Patent 4671470.
- Kamiya, R., Cheeseman, B. A., Popper, P. & Chou, T. W. (2000). Some recent advances in the fabrication and design of three dimensional textile preforms: A review, *Composite Science and Technology* 60: 33-47.
- Kazumara, M. (1988). *Tetralaxial fabric and weaving methods*, European Patent 0263392.
- Khokar, N. (2001). 3D-Weaving: Theory and Practice, *Journal of the Textile Institute*, 92(2): 193-207.
- Khokar, N. (2002a). Noobing: A nonwoven 3D fabric-forming process explained, *Journal of the Textile Institute*, 93(1): 52-74.
- Khokar, N. (2002b). *Woven 3D fabric material*, US Patent 6338367.

- Kimbara, M., Fukuta, K., Tsuzuki, M., Takahama, H., Santo, I., Hayashida, M., Mori, A. & Machii, A. (1991). *Three dimensional multi-axis fabric composite materials and methods and apparatuses for making the same*, US Patent 5076330.
- King, R. W. (1977). *Three dimensional fabric material*, US Patent 4038440.
- Ko, F.K. & Chou, T.W. (1989). *Textile Structural Composites*, New York: Elsevier.
- Lida, S., Ohmori, C. & Ito, T. (1995). *Multiaxial fabric with triaxial and quartaxial portions*, US Patent 5472020.
- Mamiliano, Dini. (1994). *Tetralaxial fabric and weaving machine for its manufacture*, US Patent 5351722.
- Mohamed, M. H. (1990). Three dimensional textiles, *American Scientist* 78: 530-541.
- Mohamed, M. H. & Bilisik, A. K. (1995). *Multilayered 3D Fabric and Method for Producing*, US Patent 5465760.
- Mohamed, M. H. & Zhang, Z. H. (1992). *Method of forming variable cross-sectional shaped three dimensional fabrics*, US Patent 5085252.
- Mood, G. I. (1996). *Multiaxial yarn structure and weaving method*, US Patent No 5540260.
- Mouritz, A. P., Bannister, M. K., Falzon, P. J. & Leong K. H. (1999). Review of applications for advanced three dimensional fiber textile composites, *Composites Part A: Applied Science and Manufacturing*, 30: 1445-1461.
- Naumann, R. and Wilkens, C. (1987). *Warp knitting machine*, US Patent 4703631.
- Nayfeh, S. A., Rohrs, J. D., Rifni, O., Akamphon, S., Diaz, M. & Warman, E. (2006). *Bias Weaving Machine*, US Patent No. 7077167.
- Ruzand, J. M. & Guenot, G. (1994). *Multiaxial three-dimensional fabric and process for its manufacture*, International Patent WO 94/20658.
- Scardino, F. L. & Ko, F. K. (1981). Triaxial woven fabrics: Part I Behavior under tensile, shear and burst deformations, *Textile Research Journal*, 51(2): 80-89.
- Schwartz, P. (1981). The mechanical behavior of fabrics having three, non-orthogonal thread directions (triaxial) and the equivalence of conventional fabrics, *PhD thesis*, NCSU.
- Skelton, J. (1971). Triaxial woven fabrics: Their structure and properties, *Textile Research Journal*, 41(8): 637-647.
- Uchida, H., Yamamoto, T., Takashima, H., Otoshima, H., Nishiyama, S. & Shinya, M. (1999). *Three dimensional weaving machine*, US Patent 6003563
- Uchida, H., Yamamoto, T. & Takashima, H. (2000). Development of low cost damage resistant composites, In: *Muratec Murata Machinery Ltd*, 14 May 2008, Available from: <http://www.muratec.net/jp>.
- Wilkens, C. (1985). *Warp knitted ware with reinforcing thread*, US Patent 4518640.
- Wunner, R. (1989). *Apparatus for laying transverse weft threads for a warp knitting machine*, US Patent 4872323.
- Yamamoto, T. & Hirokawa T. (1990). Advanced joint of 3D composite materials for space structure, *35th International Sampe symposium*, pp. 1069-1077.
- Yasui, Y., Anahara, M. & Omori, H. (1992). *Three dimensional fabric and method for making the same*, US Patent 5091246.